

SERPAC A-31

Electronics Enclosures

NOTES:
1. WHEN MACHINE OR I PLATES MODIFICATIONS ARE REQUIRED, USE THE CENTER OF THE BOX TO DIMENSION.

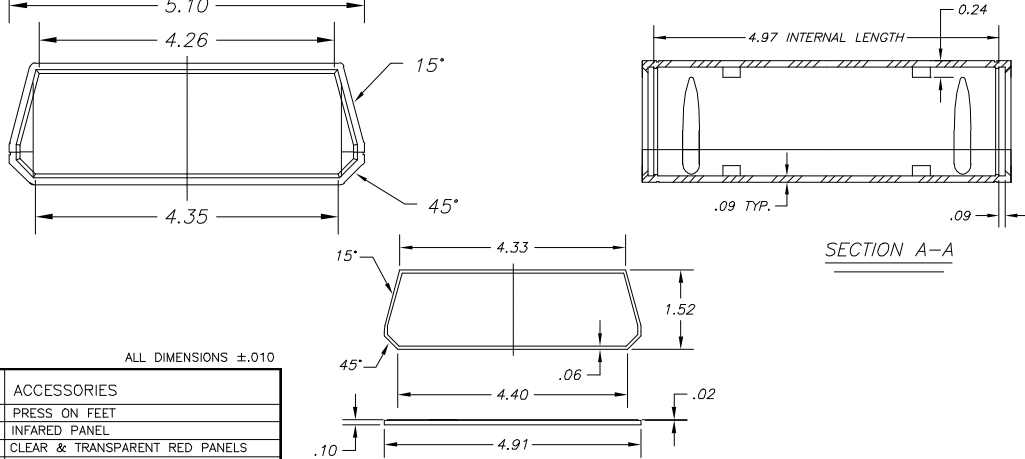
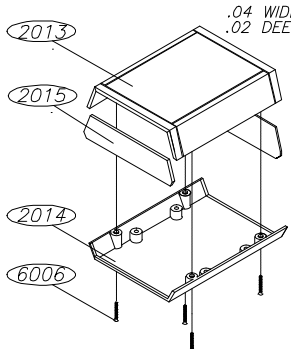
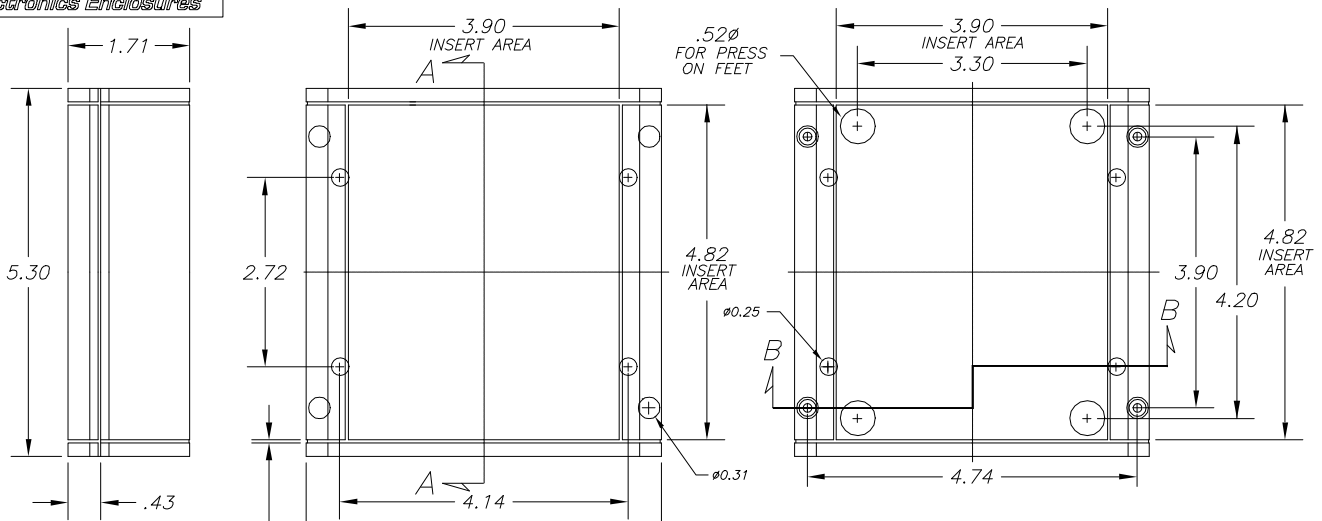

10-09-98

ALL DIMENSIONS ±.010

PART NO.	DESCRIPTION	PART NO.	ACCESSORIES
2013	PLASTIC TOP	51	PRESS ON FEET
2015	PLASTIC END PANEL	2015IR	INFRARED PANEL
2014	PLASTIC BOTTOM	2015CL	CLEAR & TRANSPARENT RED PANELS
6006	SCREW	2015DB9	9 PIN CONNECTOR END PANEL
		2015DB25	25 PIN CONNECTOR END PANEL