

# SERPAC 091

Electronics Enclosures

NOTES:  
1. WHEN MACHINE OR I PLATES MODIFICATIONS ARE REQUIRED, USE THE CENTER OF THE BOX TO DIMENSION.

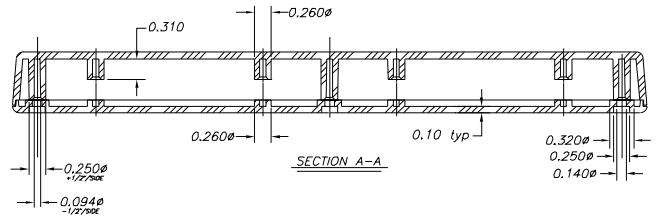
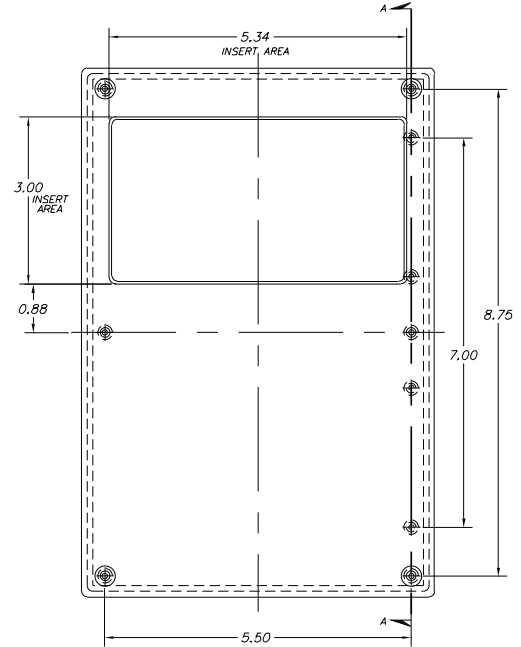
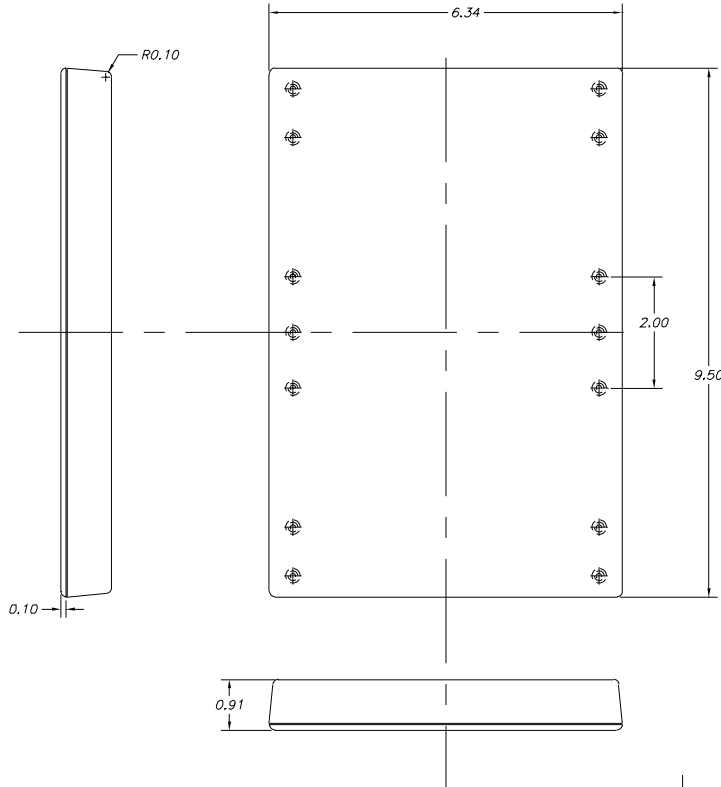

8-17-98.

ALL DIMENSIONS ± .010

ITEM	PART NO.	DESCRIPTION	ACCESSORIES	
			PART NO.	DESCRIPTION
1	91	PLASTIC TOP	51	FEET
2	09	PLASTIC BOTTOM		
3	6005	SCREWS (6)		

619 Commercial Ave. Covina, CA 91723

(626) 331-0517 Fax (626) 331-8584 <http://www.serpac.com>