

SERPAC 051

Electronics Enclosures

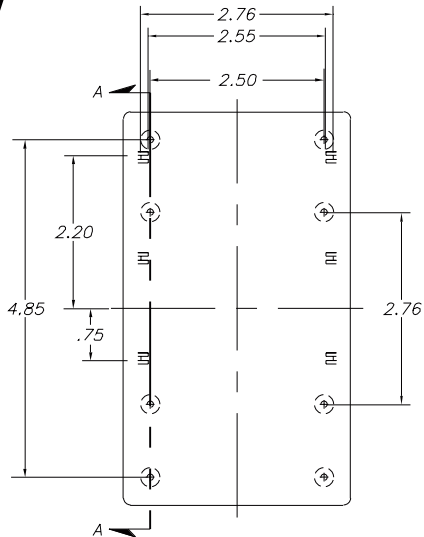

NOTES:
1. WHEN MACHINE OR I PLATES MODIFICATIONS ARE REQUIRED, USE THE CENTER OF THE BOX TO DIMENSION.

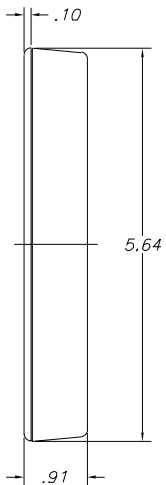
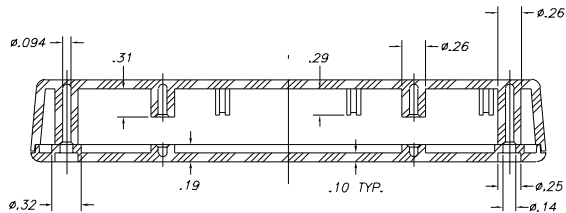
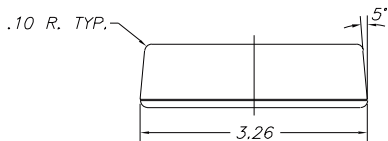
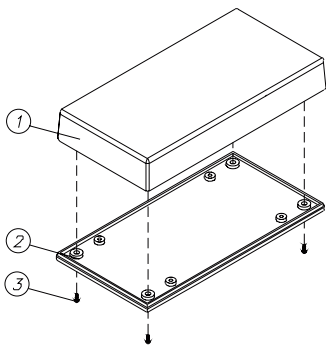
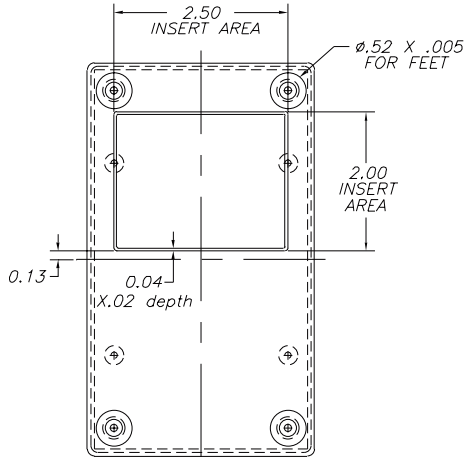

SECTION A-A

8-17-98.

ALL DIMENSIONS $\pm .010$

ITEM	PART NO.	DESCRIPTION	PART NO.	ACCESSORIES DESCRIPTION
1	51	PLASTIC TOP	51	FEET
2	05	PLASTIC BOTTOM	350	PROTOTYPE GRID BOARD (HORIZ.)
3	6005	SCREWS (4)	450	PROTOTYPE CLAD BOARD (HORIZ.)